

TANDEM TYING STATION

Double your efficiency with the PakTyer 2000™ Tandem Tyer. This specially designed machine features dual tying arms that will help users process products in less time by making two ties simultaneously. All the features and benefits you have come to know and expect with the Felins tying machines are built in; direct drive, sealed motor and gearbox, durability, long term performance and minimal maintenance. The Tandem Tyer is offered in five different sizes and will accommodate a wide variety of bundle sizes.



REDUCE LABOR

With a single stroke the PakTyer 2000™ Tandem Tyer will place two individual ties of polytape, twine or elastomer around your product bundle. No longer will you have to feed the product twice to make two ties. The Tandem Tyer is ideal for tying laundry, blankets, comforters, rugs, large garment pieces, belts, industrial goods and other oversized items.

REDUCE COSTS

Felins tying materials are designed to provide maximum efficiency in the tying process to further reduce the total cost. We stock a variety of tying materials including polytape, twine and elastomer.

EQUIPMENT FEATURES

Available in five standard sizes with product height options ranging from 6” to 16” and with tying arms spaced 6.5” to 8” apart. A variety of activation methods are available; foot trip, ultra light or heavy duty table top trip. Standard features include a stainless steel table and durable powder coated enclosure mounted on rolling casters for easy positioning. Additional options include the Vacuum Tail Removal System (VTR) and an Obstruction Sensor for added safety. Custom sizes are also available to meet your specific product and processing needs.

EQUIPMENT SPECIFICATIONS

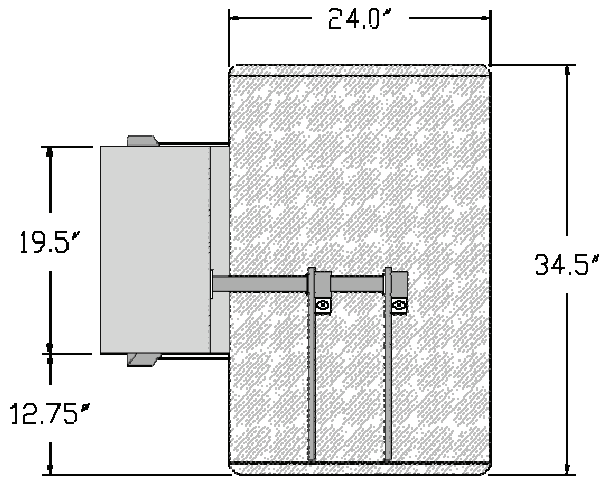

FELINS
TANDEM TYERS

