

### OFFSET TYING STATION

Felins Offset PakTyer 2000 bundling machines are the most advanced tyers available. Felins has combined the latest in state of the art technology with its renowned heavy duty construction to offer the most reliable bundling machine on the market used to replace rubber banding and twist tying.



- Bundling
- Bunching
- Tying
- Banding

**SPECIAL FEATURES** of our elastic and greenhouse tyers include, specially designed work tables to allow for the bundling of seedlings, flowers, shrubs, and vegetables without bruising the products. Dirt and water resistant construction enables this machine to be used in the harshest environments. Engineered with iron and steel components for durability in industrial environments. And with our unique offset design and extended throat length, this unit can be operated from either side for maximum flexibility and efficiency.

**COMPACT AND PORTABLE**, this table top unit is perfect for even the smallest work areas. It is also available with an optional cart for mobility. The six inch height clearance gives the offset nursery tyer the capability to tie any length item in one second.

The versatility of the Elastic Tyer 2000 enables it to operate with various elastic tying media as needed. With its built in twine holder and easy to thread twine delivery arm, our PakTyer is the simplest machine to operate. Other non-elastic tying media can be used in the machine, as well. The offset tyer can also be easily mounted into a variety of automated systems - and it is invertible!

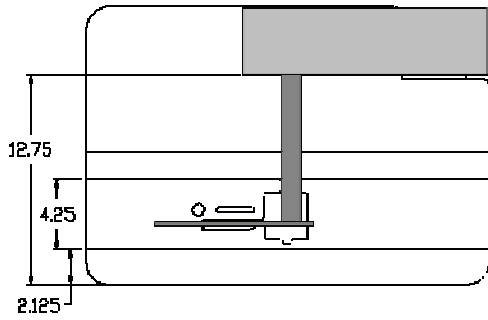

## FELINS OFFSET TYERS

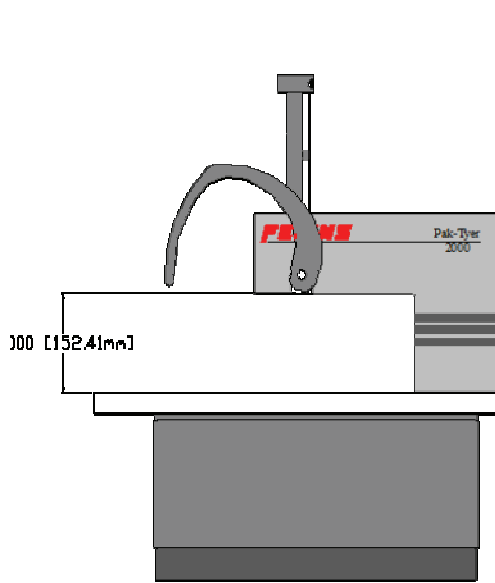
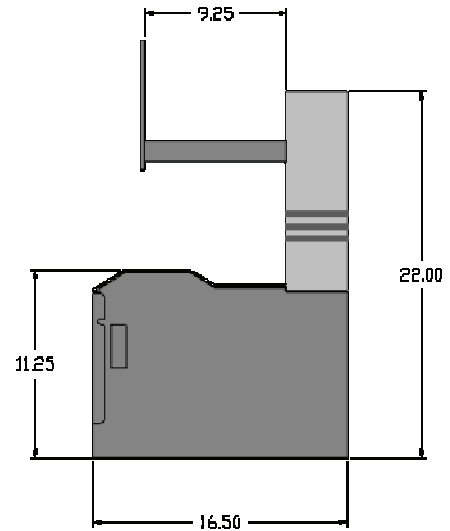
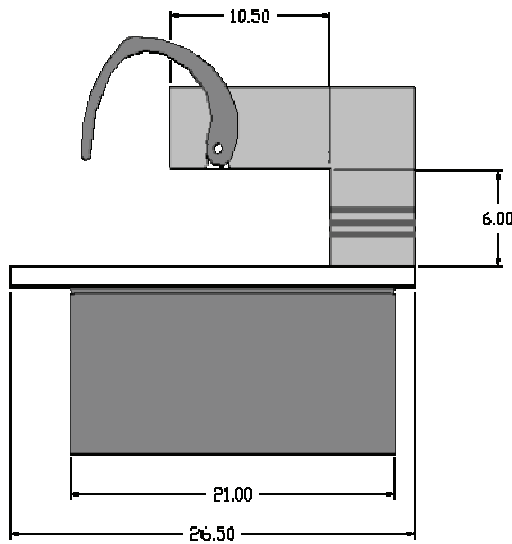

2000-6 OFFSET  
NURSERY TYER

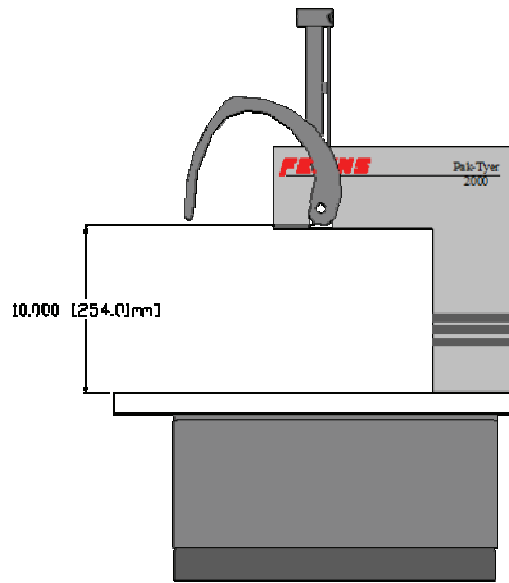

2000-10 OFFSET  
NURSERY TYER