

# DEFENDER RT

Semi-Automatic Rotary Arm Stretch-Wrapper



## Features

- Easily wraps unstable or heavy loads
- Wraps any colour product
- Saves 65% on film costs
- Adjustable film tension from control panel
- Uses 20 in. machine film or 18 in. prestretched or hand film
- Lifetime guarantee on prestretch rollers
- 3 year machine warranty
- Available in four configurations:
  - Wall mountable
  - Beam mountable
  - Portable and free-standing
  - Post-mount frame
- Soft-start and stop on arm drive
- Solid-state arm safety-stop
- Non-Proprietary Components

# DEFENDER RT

## Semi-Automatic Rotary Arm Stretch-Wrapper

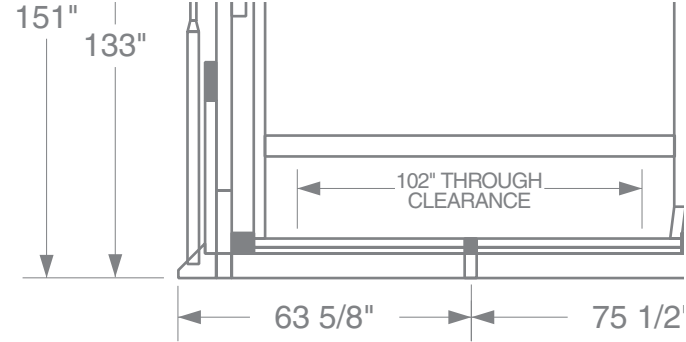

### Standard Features

#### Wrapping Features

- Power on/off switch
- Start button
- Emergency stop button
- Adjustable arm speed (0-14 RPM)
- Adjustable carriage speed
- Adjustable film tension
- Manual carriage control
- Manual arm control
- Separate top and bottom wrap selector switch (0-9)
- Selectable over-wrap on load (1-9")
- Triple beam auto-height photoeye to sense any colour product
- PLC Controller
- SCR speed controls provide arm with soft start and stop
- Dynamic braking
- Breaker resets on panel
- Positive home alignment
- Emergency stop if photoeye detects obstacles in arm's path

#### Main Frame and Arm

- Tubular steel construction
- 1/2 HP, TEFC, 90V DC motor
- Heavy-duty ANSI #50 chain drive

#### Film Carriage

- 20" Samuel E-Z load non-slip pre-stretch carriage
- Closing the door automatically threads film
- Coated rollers prevent film from slipping and reduce neckdown
- Lifetime guarantee on prestretch rollers
- Power pre-stretch allows film to be stretched by 60 to 300% (set to customer's needs)
- Full corner compensation to prevent load crushing or film breakage

### Specifications

Electrical Supply	115V 12 amp
UL/CSA	Approved components
Load size	52" x 52"
Load Heights	20" to 96"
Load Weights	Unlimited
Production	30-40 loads per hour (depending on configuration)

Machines for larger, higher, and heavier loads are available.

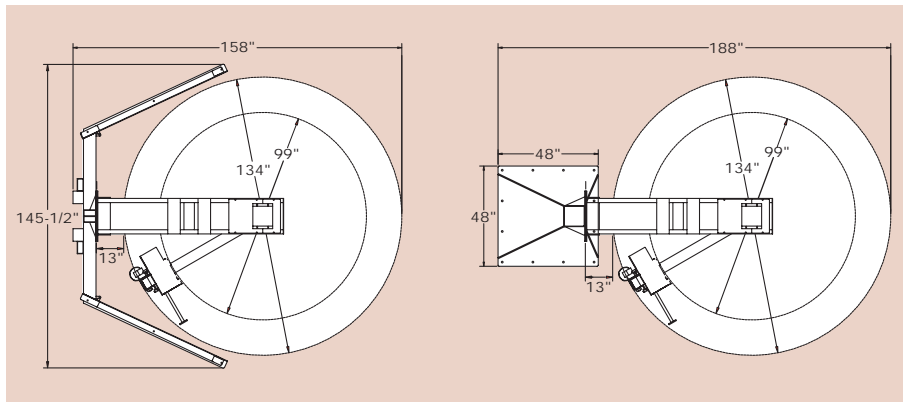

#### Available Options

- Auto-film Cutter
- Cold Temperature Package
- Cycle Counter
- Foot-Pedal Cycle Start Switch
- Remote Lanyard Start Switch
- Carriage Upgrade from Standard 20" to 30"
- Carriage-mounted, Single Acting, Manually Adjustable Roping Device
- Carriage-mounted, Double Acting, Manually Adjustable Roping Device
- Photo-eye for Round or Black Loads
- Warning Beacon
- Wash-down Motors
- CSA/UL Approval
- Increased Maximum Load Diagonal
- Wrap Height Extension

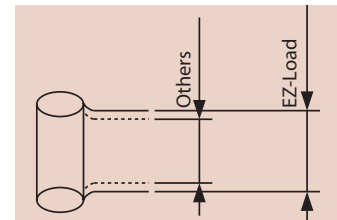

High-efficiency EZ-Load pre-stretch carriage minimizes neck-down and improves film yield.

#### Samuel Strapping Systems Packaging Systems Group

1050 Brevik Place  
Mississauga, ON  
L4W 3V9

Tel: (905) 238-7778  
Fax: (905) 238-7046

For all other locations  
call 1-800-694-2307

www.samuelstrapping.com

Distributed by:

Miller/Bevco  
2855 Southwest Blvd.  
Kansas City, MO 64108  
Toll free 800-821-2177  
Fax: 816-561-8595  
Sales@MillerBevco.com  
www.MillerBevco.com