

LITTLE DAVID®



LOVESHAW an **TW** Company

Quality Engineered

LEGEND SERIES **RANDOM** CASE SEALER



Photo shows optional exit pack table and optional casters.

We Build Random Legends That Last.

Loveshaw has once again designed a Case Sealer to meet customer demands. The **Little David® Legend Series™ Random Case Sealer** incorporates a single mast design with an enclosed head lifting cylinder, a sealed drive system and the heavy-duty CaseLocker ST™ cartridge that requires no lubrication. This unit also has a head raising air switch to aid in bottom tape roll change. The Random Legend comes standard with extended side rails and a roller in-feed table with integrated roller switch to operate rails. Another standard feature is a lockable head height and side rails, which allows the Random Legend to operate as a Uniform Case Sealer. Just one look at the Random Legend and you know why it will stand the test of time. After all, it is a Legend.

- Light touch "Live" roller table for centering
- Built in adjustable "Burp" for head, allowing box to exit
- Clean look, no hose/wire guards exposed
- Main air shut off with lockout tag out tab
- Light touch head paddle
- Back to back feature, reduces head travel for uniform runs

Features:

Reliable Performance. Warranty covers all components for 1 year, gear reducer for 2 years and cartridge for 3 years.* Wider belts and wider hold down strips securely grip box for consistent tape closure. Belts are self-tensioning and self-centering.

*Moving & wear parts are not included. Other restrictions may apply. Consult Loveshaw or your authorized Little David Distributor for details.

Quick Changeover. Lockable head height and side rail allow the Random Legend to operate in both Random and Uniform Modes.

Flexible. Unit can change as your needs change. Tapes boxes from 3" to 24" high. Converts to 2" or 3" wide tape. Interchangeable top and bottom CaseLocker ST™ cartridges.*

*Change parts required to convert tape widths.

Heavy Duty Design. Structural grade tubing supports the single mast construction. Heavy duty CaseLocker ST™ side threading cartridge.

Easy Operation. Plug in operation. Minimal operator training. Sealed drive system and CaseLocker ST™ cartridge require no lubrication.

Safe. Single mast design allows clear access. The knife guard system of the CaseLocker ST™ only allows the blade to be exposed when the rollers have been depressed.

Specifications:

Power Requirements: 115 volts, single phase, 60 cycle (10 amp circuit) (other voltage available, consult Loveshaw)

Air Requirements: 10 SCFM @ 70 PSI

Operating Speed: Continuous belt drive; 80'/min.(24 m/min.) (Production rate depends on box size and operator dexterity)

Weight: 275 lbs (125 kg) un-crated

Case Capacity: (with 2" wide Caselocker ST™ Cartridge)
Min: Height 3" (76 mm), Width 4-1/2" (114 mm), Length 4-1/2" (114 mm)
Max: Height 24" (610 mm),* Width 22" (559 mm), Length infinite

*Conveyor height minimum is 22.25" (565 mm).

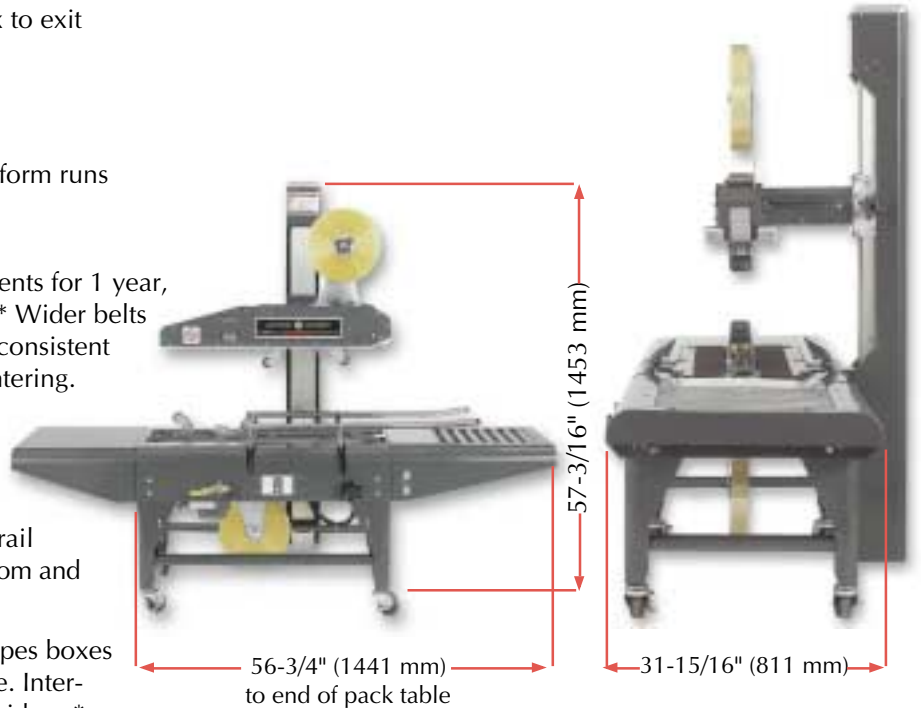

Photos show optional exit pack table and optional casters. Overall height based on standard 22-1/4" conveyor height without optional casters.



Top cartridge tips back on head for tape threading.



Leg extensions are clearly marked with graduated scales in both inches and metric dimensions. Leg adjustments slide and lock in place to accommodate conveyor heights from 22.25" to 32.25" (565 mm to 819 mm).

visit
www.loveshaw.com

LOVESHAW
an ITW Company

LITTLE DAVID PRODUCTS DIVISION
Route 296 Box 83
South Canaan, PA 18459
(570) 937.4921 Fax (570) 937.3229
1(800) 572.3434

LOVESHAW Europe

A Division of ITW Ltd.
Unit 9 Brunel Gate,
West Portway Industrial Estate
Andover, Hampshire England SP 10 3 SL
Tel: (1264) 357511 Fax: (1264) 355964

